

# Instruction Manual



## **P6021** **60 MHz Current Probe** **070-0947-05**

### **Warning**

The servicing instructions are for use by qualified personnel only. To avoid personal injury, do not perform any servicing unless you are qualified to do so. Refer to all safety summaries prior to performing service.

**[www.tektronix.com](http://www.tektronix.com)**



Copyright © Tektronix, Inc. All rights reserved.

Tektronix products are covered by U.S. and foreign patents, issued and pending. Information in this publication supercedes that in all previously published material. Specifications and price change privileges reserved.

Tektronix, Inc., P.O. Box 500, Beaverton, OR 97077

TEKTRONIX and TEK are registered trademarks of Tektronix, Inc.

LUBRIPLATE is a registered trademark of the Fiske Brothers Refining Co.

POSIDRIV is a registered trademark of the Philips Screw Co.

## WARRANTY

Tektronix warrants that this product will be free from defects in materials and workmanship for a period of one (1) year from the date of shipment. If any such product proves defective during this warranty period, Tektronix, at its option, either will repair the defective product without charge for parts and labor, or will provide a replacement in exchange for the defective product.

In order to obtain service under this warranty, Customer must notify Tektronix of the defect before the expiration of the warranty period and make suitable arrangements for the performance of service. Customer shall be responsible for packaging and shipping the defective product to the service center designated by Tektronix, with shipping charges prepaid. Tektronix shall pay for the return of the product to Customer if the shipment is to a location within the country in which the Tektronix service center is located. Customer shall be responsible for paying all shipping charges, duties, taxes, and any other charges for products returned to any other locations.

This warranty shall not apply to any defect, failure or damage caused by improper use or improper or inadequate maintenance and care. Tektronix shall not be obligated to furnish service under this warranty a) to repair damage resulting from attempts by personnel other than Tektronix representatives to install, repair or service the product; b) to repair damage resulting from improper use or connection to incompatible equipment; or c) to service a product that has been modified or integrated with other products when the effect of such modification or integration increases the time or difficulty of servicing the product.

**THIS WARRANTY IS GIVEN BY TEKTRONIX WITH RESPECT TO THIS PRODUCT IN LIEU OF ANY OTHER WARRANTIES, EXPRESSED OR IMPLIED. TEKTRONIX AND ITS VENDORS DISCLAIM ANY IMPLIED WARRANTIES OF MERCHANTABILITY OR FITNESS FOR A PARTICULAR PURPOSE. TEKTRONIX' RESPONSIBILITY TO REPAIR OR REPLACE DEFECTIVE PRODUCTS IS THE SOLE AND EXCLUSIVE REMEDY PROVIDED TO THE CUSTOMER FOR BREACH OF THIS WARRANTY. TEKTRONIX AND ITS VENDORS WILL NOT BE LIABLE FOR ANY INDIRECT, SPECIAL, INCIDENTAL, OR CONSEQUENTIAL DAMAGES IRRESPECTIVE OF WHETHER TEKTRONIX OR THE VENDOR HAS ADVANCE NOTICE OF THE POSSIBILITY OF SUCH DAMAGES.**

# Table of Contents

<b>General Safety Summary</b> .....	<b>iii</b>
<b>Service Safety Summary</b> .....	<b>v</b>
<b>Contacting Tektronix</b> .....	<b>vi</b>
<b>Operator Information</b> .....	<b>1</b>
Description .....	1
Installation .....	1
Operating Considerations .....	4
<b>Service Information</b> .....	<b>7</b>
Warranted Characteristics .....	7
Typical Characteristics .....	10
Circuit Description .....	12
Performance Verification .....	14
Adjustment Procedures .....	16
Maintenance .....	26
<b>Replaceable Electrical Parts</b> .....	<b>31</b>
Parts Ordering Information .....	31
Using the Replaceable Electrical Parts List .....	31
<b>Replaceable Mechanical Parts</b> .....	<b>37</b>
Parts Ordering Information .....	37
Using the Replaceable Mechanical Parts List .....	37
<b>Index</b> .....	<b>43</b>

## List of Figures

<b>Figure 1: The P6021 Probe and Termination</b> .....	<b>2</b>
<b>Figure 2: Insertion Impedance of the P6021</b> .....	<b>5</b>
<b>Figure 3: Probe and Termination Input Current vs. Frequency Derating</b> .....	<b>9</b>
<b>Figure 4: Typical P6021 Phase Response</b> .....	<b>11</b>
<b>Figure 5: P6021 Schematic Diagram</b> .....	<b>13</b>
<b>Figure 6: Connecting the Probe to the Calibration Fixture</b> .....	<b>18</b>
<b>Figure 7: Location of Probe Adjustments</b> .....	<b>19</b>
<b>Figure 8: Location of Termination Adjustments</b> .....	<b>20</b>
<b>Figure 9: Disassembling the Probe</b> .....	<b>27</b>
<b>Figure 10: P6021 Probe Component Location</b> .....	<b>35</b>
<b>Figure 11: P6021 Termination Component Location</b> .....	<b>35</b>
<b>Figure 12: P6021 Exploded View</b> .....	<b>41</b>

## List of Tables

<b>Table 1: Warranted Electrical Characteristics</b> .....	<b>7</b>
<b>Table 2: Warranted Environmental Characteristics</b> .....	<b>8</b>
<b>Table 3: Maximum Ratings</b> .....	<b>8</b>
<b>Table 4: Certifications and Compliances</b> .....	<b>9</b>
<b>Table 5: Electrical Characteristics</b> .....	<b>10</b>
<b>Table 6: Mechanical Characteristics</b> .....	<b>11</b>
<b>Table 7: Equipment List</b> .....	<b>15</b>

# General Safety Summary

Review the following safety precautions to avoid injury and prevent damage to this product or any products connected to it. To avoid potential hazards, use this product only as specified.

*Only qualified personnel should perform service procedures.*

## To Avoid Fire or Personal Injury

**Connect and Disconnect Properly.** Do not connect or disconnect probes or test leads while they are connected to a voltage source.

**Observe All Terminal Ratings.** To avoid fire or shock hazard, observe all ratings and markings on the product. Consult the product manual for further ratings information before making connections to the product.

Connect the ground lead of the probe to earth ground only.

Do not apply a potential to any terminal, including the common terminal, that exceeds the maximum rating of that terminal.

**Do Not Operate Without Covers.** Do not operate this product with covers or panels removed.

**Avoid Exposed Circuitry.** Do not touch exposed connections and components when power is present.

**Do Not Operate With Suspected Failures.** If you suspect there is damage to this product, have it inspected by qualified service personnel.

**Do Not Operate in Wet/Damp Conditions.**

**Do Not Operate in an Explosive Atmosphere.**

**Keep Product Surfaces Clean and Dry.**

## Symbols and Terms

**Terms in this Manual.** These terms may appear in this manual:



---

**WARNING.** *Warning statements identify conditions or practices that could result in injury or loss of life.*

---



---

**CAUTION.** *Caution statements identify conditions or practices that could result in damage to this product or other property.*

---

**Terms on the Product.** These terms may appear on the product:

DANGER indicates an injury hazard immediately accessible as you read the marking.

WARNING indicates an injury hazard not immediately accessible as you read the marking.

CAUTION indicates a hazard to property including the product.

**Symbols on the Product.** The following symbols may appear on the product:



CAUTION  
Refer to Manual



Double  
Insulated



Protective Ground  
(Earth) Terminal



## Service Safety Summary

Only qualified personnel should perform service procedures. Read this *Service Safety Summary* and the *General Safety Summary* before performing any service procedures.

**Do Not Service Alone.** Do not perform internal service or adjustments of this product unless another person capable of rendering first aid and resuscitation is present.

To avoid electric shock, do not touch exposed connections.

## Contacting Tektronix

<b>Phone</b>	1-800-833-9200*
<b>Address</b>	Tektronix, Inc. Department or name (if known) 14200 SW Karl Braun Drive P.O. Box 500 Beaverton, OR 97077 USA
<b>Web site</b>	<a href="http://www.tektronix.com">www.tektronix.com</a>
<b>Sales support</b>	1-800-833-9200, select option 1*
<b>Service support</b>	1-800-833-9200, select option 2*
<b>Technical support</b>	Email: <a href="mailto:techsupport@tektronix.com">techsupport@tektronix.com</a> 1-800-833-9200, select option 3* 1-503-627-2400 6:00 a.m. – 5:00 p.m. Pacific time

---

\* This phone number is toll free in North America. After office hours, please leave a voice mail message.  
Outside North America, contact a Tektronix sales office or distributor; see the Tektronix web site for a list of offices.

# Operator Information

Thank you for choosing a Tektronix current probe. This manual describes the P6021 current probe with passive termination and provides information about making measurements with the probe.

## Description

The P6021 current probe converts an alternating current waveform to a voltage that can be displayed and measured on an oscilloscope display. The probe provides accurate current measurements over a wide range of frequencies and allows you to measure current without breaking the circuit.

The P6021 probe is compatible with general purpose oscilloscopes having a 1 M $\Omega$  input impedance. The P6021 probe comes with a passive termination that matches oscilloscope and probe impedance, optimizes the probe performance, and provides two sensitivity settings.

In the standard configuration, the P6021 probe comes with a 5-foot cable and termination. The following option is also available.

**Option 03.** 9-foot cable with termination

## Installation

This section describes both attaching the probe to an oscilloscope and using the standard accessories with the probe.

To ensure the best performance from your probe and oscilloscope measurement system, check that the probe and oscilloscope are appropriately matched. The oscilloscope inputs should use BNC connectors and have an impedance of 1 M $\Omega$ .

Figure 1 shows the probe and various parts referred to in this manual.

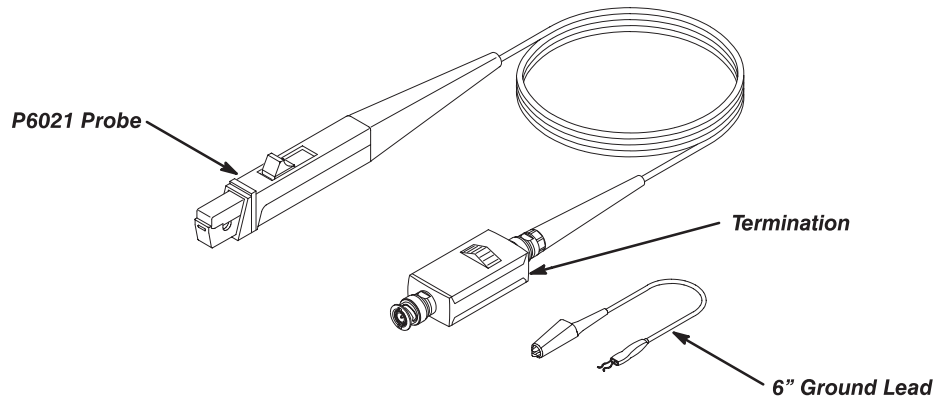

Figure 1: The P6021 Probe and termination

### Attaching the Probe and Termination to an Oscilloscope

Attach the probe to the termination as shown in Figure 1.

An alligator-style ground clip is supplied to improve EMI rejection at high frequencies (2 MHz and above). Snap the ground lead to the probe transformer post and attach the alligator clip directly to RF ground. This will reduce ringing and help bypass capacitively-coupled RF currents that can flow into the probe cable.



---

**WARNING.** To avoid injury or equipment damage, remove power from an uninsulated wire before clamping the current probe around it. When the probe slides are open, the exposed ferrite core pieces are not insulated. Also, never disconnect the probe from the termination when the probe is connected to a live conductor.

To avoid damaging the probe, do not disconnect the probe termination and leave the P6021 clamped around the conductor when measuring high currents. Leaving the probe cable unterminated can cause a high voltage to develop in the secondary winding, which may damage the current probe transformer.

---

### Using the Standard Accessories

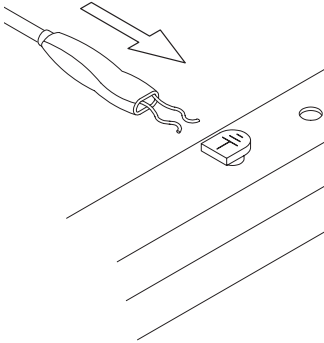

Your P6021 is shipped with the following accessories:

- **This instruction manual** — Read these instructions to familiarize yourself with the features, specifications, and operation of the P6021 current probe.
- **6-inch ground lead** — Use the 6-inch ground lead to ground the shield around the probe transformer at the probe end of the cable. This allows you to move the ground connection closer to the circuit that you are measuring, thereby improving high frequency response. The ground lead clips onto the ground connector on the bottom of the probe as shown.

Please refer to the parts list in the section entitled *Replaceable Mechanical Parts* for part numbers.

### Optional Accessories

Your P6021 may be used with the following optional accessory:

- **CT-4 Current Probe** — The CT-4 is a robust clip-on transformer that extends the current range of the P6021 up to 1000 amps (provided the amp-second rating is not exceeded). The CT-4 has receptacles for current probes in either 20:1 or 1000:1 step-down ratios.

## Operating Considerations

The information in this section will help you make effective use of your P6021 probe.

### Features and Controls

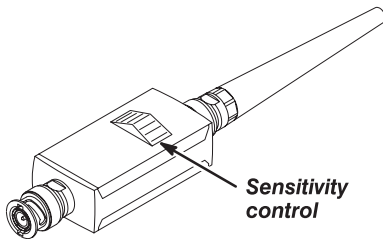

- Sensitivity Control** — The P6021 termination has a control that allows you to select probe sensitivity. The switch has two positions: 2 mA/mV and 10 mA/mV. When the control is in the 2 mA/mV position, the oscilloscope displays 1 mV for every 2 mA of current in the circuit under test. When the control is in the 10 mA/mV position, the oscilloscope displays 1 mV for every 10 mA of current in the circuit under test.

You can set vertical scale on the oscilloscope to any scale factor, as determined by the signal amplitude. To calculate the overall vertical scale factor for the oscilloscope, probe, and termination, multiply the termination sensitivity control setting by the vertical scale factor of the oscilloscope. For example, if the termination control is set to the 10 mA/mV position and the oscilloscope to a vertical scale of 20 mV/division, the overall scale factor is 10 X 20, or 200 mA/division.

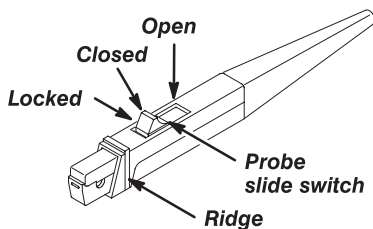

- Probe Slide Switch** — The slide switch on the probe has three positions: open, closed, and locked. Use your thumb to move the probe slide switch. The switch is spring loaded so that it automatically moves from the open to closed positions.

#### To Use the Probe:

- Pull the slide switch toward you, and hold the switch in position.
- Place the conductor-under-test inside the exposed transformer core. The arrow on the transformer end of the probe indicates conventional current flow. If you place the probe on the conductor so that the arrow on the probe matches conventional current flow through the conductor, orientation of the displayed waveform will be correct.
- Release the switch, allowing the probe to close.
- Lock the slide switch. To lock the switch, push it firmly toward the transformer (the switch will move only about 1/8th inch). Locking the switch assures maximum contact between the two halves of the transformer secondary. The conductor now becomes the primary of the transformer. (When measuring current, always check that the probe slide switch is moved completely forward into the locked position.)



**WARNING.** To prevent shock when measuring uninsulated conductors, keep your hands and fingers behind the ridge on the probe head.

**Insertion Impedance**

When you insert a conductor into the probe, you add impedance to the circuit you are measuring. This additional impedance affects signals; this is particularly important if you are measuring fast rise times. Figure 2 illustrates the equivalent circuit with the additional impedance introduced by the P6021.

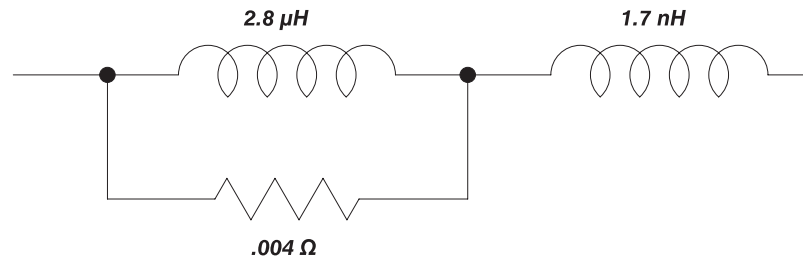

**Figure 2: Insertion Impedance of the P6021**

**Minimizing Loading Effect**

To minimize the loading effect of the probe, clamp it at the low or ground end of a component lead when possible. This method also minimizes noise or stray signal interference.

**Increasing Probe Sensitivity**

You can increase the current sensitivity of the probe by increasing the number of times a conductor passes through it. For example, if the conductor loops through the probe twice (a two-turn primary winding), the secondary current is doubled.

For example, suppose you set the termination sensitivity to 2 mA/mV and the oscilloscope vertical scale to 10 mV/division. Ordinarily, this would result in the equivalent of 2 X 10, or 20 mA/division. However, if the conductor is looped through the probe twice, the vertical scale is divided by two, resulting in the equivalent of 10 mA/division.

Looping the conductor twice effectively doubles vertical sensitivity; however, impedance from the probe winding is also reflected into the circuit being measured. This impedance is proportional to the square of the number of loops. This additional impedance affects signals; this impedance is particularly important when you are measuring high-frequency current waveforms or waveforms with fast rise times.

**Probe Shielding**

The P6021 is shielded to minimize the effect of external magnetic fields. However, strong fields can interfere with the current signal being measured. If you suspect that an external field is interfering with your measurement, remove the probe from the conductor, but keep it in the same location as when you made the suspect measurement. If a signal still appears on the oscilloscope, try to measure the conductor current at a point farther from the location of the magnetic field.

If you must measure current in the presence of a strong magnetic field, you can minimize its interference by using two current probes and a differential-input oscilloscope. To do so, follow these steps.

1. Connect the probes (with termination) to the positive and negative inputs of the oscilloscope.
2. Clamp one probe around the conductor whose current you want to measure.
3. Place the other probe as close as possible to the first. Ensure that its slide switch is completely closed, without a conductor inside it.
4. Set the oscilloscope to subtract the component of the signal that is common to both probes.
5. Adjust the positions of the probes for best results. It may be difficult to eliminate the undesirable signal completely, due to differences between the probes or their terminations.

**Droop**

The flat-top response of any AC current probe displays a certain amount of droop. This is caused by probe inductance loading the source impedance, causing an L/R exponential decay. For short pulse widths, the response looks nearly flat. The amount of droop can be calculated from the following relationship:

$$\% \text{ Droop} = 200 (\pi) T f$$

*where:*

T=pulse duration in microseconds

f=lower 3 dB frequency of probe in Hertz

For example, to calculate the percent droop of a 100  $\mu$ s pulse measured with a P6021 probe:

In the 10 mA/mV position, f=120 Hz

$$\begin{aligned} \% \text{ Droop} &= 200 (\pi) T f \\ &= 200 (\pi) (100 \times 10^{-6}) (120) \\ &= 0.075\% \end{aligned}$$

# Service Information

## Warranted Characteristics

This section lists the various warranted characteristics that describe the P6021 Current Probe. Included are warranted electrical and environmental characteristics.

Warranted characteristics are described in terms of quantifiable performance limits which are warranted.

The electrical characteristics listed in Table 1 apply under the following conditions:

- The probe and instrument must be in an environment whose limits are described in Table 2.

**Table 1: Warranted electrical characteristics**

Characteristic	Information
Sensitivity	2 mA or 10 mA for each mV at oscilloscope input, selected by termination sensitivity control
Midband Accuracy	±3% at 10 kHz to 30 kHz
System Bandwidth (with BW>200 MHz oscilloscope)	
2 mA/mV	450 Hz to 60 MHz
10 mA/mV	120 Hz to 60 MHz
Probe Rise Time	≤5.8 ns
Step Response	<i>Because the oscilloscope input capacitance becomes a part of the termination network, the step response will vary with different oscilloscopes</i>
Aberrations (probe and termination at either sensitivity setting.)	≤10% peak-to-peak within 50 ns of step; ≤2% peak-to-peak thereafter

**Table 2: Warranted environmental characteristics**

Characteristic	Information
Temperature range	
Operating	-0°C to +50°C (+32°F to +122°F)
Nonoperating	-40°C to +65°C (-40°F to +149°F)
Altitude	
Operating	To 2,000 m (6,561 ft), <300 V CAT I To 4,572 m (15,000 ft), <150 V, CAT I
Nonoperating	To 15,240 m (50,000 ft)

**Table 3: Maximum ratings**

Characteristic	Information
Maximum Continuous (CW) Current	Refer to Figure 3 for frequency derating curves
2 mA/mV	5 A <sub>p-p</sub> sine wave between 1.2 kHz and 5 MHz
10 mA/mV	15 A <sub>p-p</sub> sine wave between 300 Hz and 5 MHz
Maximum Pulse Current	250 A peak, not to exceed 500(A · μs) or 5 A <sub>RMS</sub> . An (A · s) product greater than 500(A · μs) reduces probe output to zero due to core saturation
Maximum Working Input Voltage (uninsulated conductors)	300 VAC or VDC, CAT I, and 600 V <sub>pk</sub> limited to <10 ms and <25% duty factor.

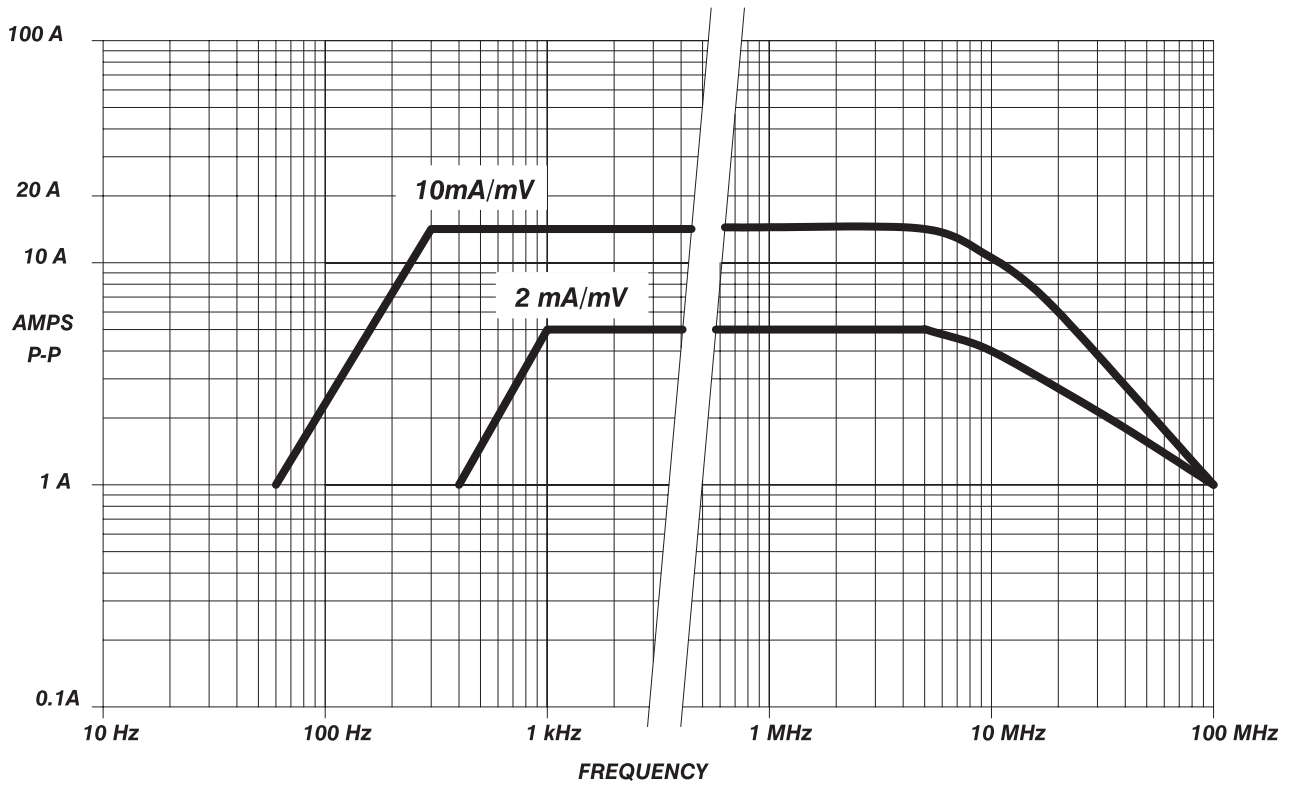

Figure 3: Probe and termination input current vs. frequency derating

Table 4: Certifications and compliances

EC Declaration of Conformity – Low Voltage

Compliance was demonstrated to the following specifications as listed in the Official Journal of the European Communities:

Low Voltage Directive 73/23/EEC, as amended by 93/68/EEC

EN 61010-1/A2	Part 1: General Requirements Safety requirements for electrical equipment for measurement, control, and laboratory test
EN 61010-2-032:1995	Part 2-032: Particular requirements for hand-held current clamps for electrical measurements and test
Listed UL1244, Third Edition	Electrical and electronic measuring and test equipment

**Table 4: Certifications and compliances (Cont.)**

Installation Category Descriptions	
Terminals on this product may have different installation category designations. The installation categories are:	
CAT III	Distribution-level mains (usually permanently connected). Equipment at this level is typically in a fixed industrial location
CAT II	Local-level mains (wall sockets). Equipment at this level includes appliances, portable tools, and similar products. Equipment is usually cord-connected
CAT I	Secondary (signal level) or battery operated circuits of electronic equipment
Pollution Degree 2	Do not operate in environments where conductive pollutants may be present.

## Typical Characteristics

This section lists the various typical characteristics that describe the P6021 Current Probe. Included are typical electrical and mechanical characteristics.

Typical characteristics are described in terms of typical or average performance. Typical characteristics are not warranted.

**Table 5: Electrical characteristics**

Characteristic	Information
Tilt	
2 mA/mV	2.8% or less within 10 $\mu$ s of step
10 mA/mV	7.5% or less within 100 $\mu$ s of step
Maximum DC saturation	0.5 A
Signal Delay	
5-foot probe with termination	Approximately 9 ns
9-foot probe with termination	Approximately 15.8 ns
Insertion Impedance	0.03 $\Omega$ or less at 1 MHz, increasing to 1.0 $\Omega$ or less at 60 MHz

**Table 6: Mechanical characteristics**

Characteristic	Information	
Probe Cable Length	5 ft or 9 ft	1.5 m or 2.75 m
Net Weight:		
Probe and 5-foot cable	3.60 oz	≈103 gm
Probe and 9-foot cable	4.4 oz	≈125 gm
Termination	1.7 oz	≈48 gm
Termination	L 3.47 in W 1.10 in H 0.86 in	88 mm 28 mm 22 mm
Probe Body	L 7.9 in W 0.63 in H 1.25 in	200 mm 16 mm 32 mm
Maximum Conductor Diameter	0.141 in	3.58 mm

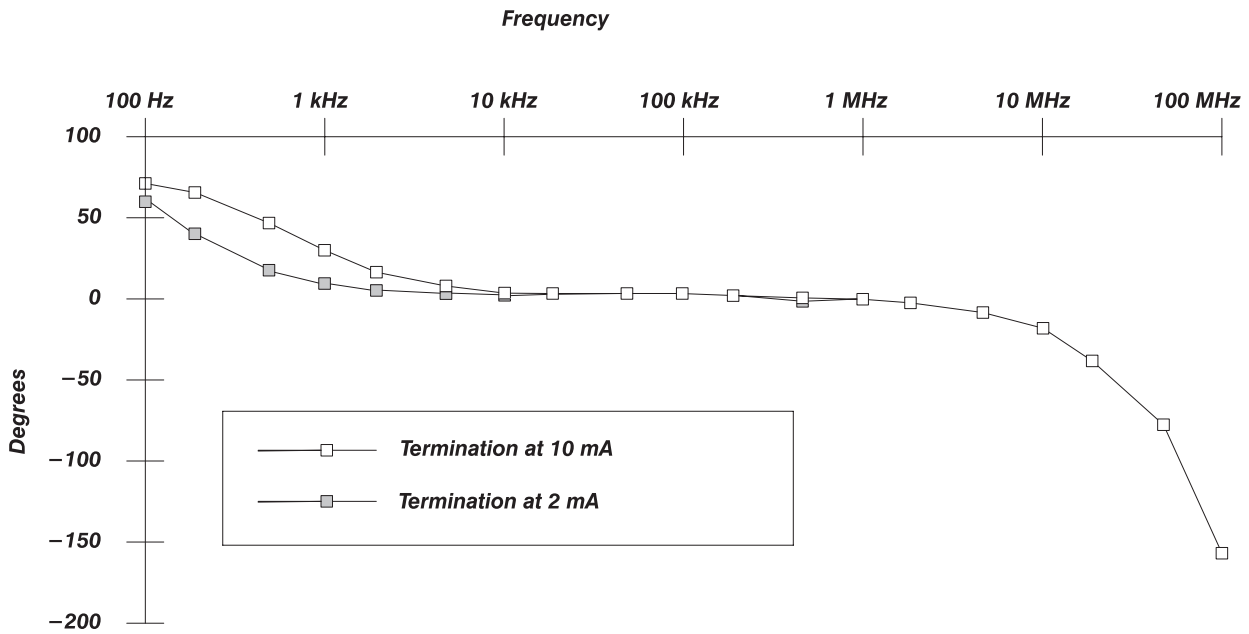

**Figure 4: Typical P6021 phase response**

## Circuit Description

This section describes the circuits in the P6021 current probe and termination. For the schematic diagram of the probe and termination, see Figure 5 on page 13.

### Current Probe

The P6021 current probe consists of a current transformer mounted in the nose of the probe head case, an impedance-matching network, and an internal switch to disconnect the transformer shield from ground.

The transformer contains a two-section U-shaped ferrite core. One section is stationary; the other is mechanically movable to permit closing the core around the conductor being measured. The conductor under test forms a one-turn primary winding for the transformer; the windings around the stationary portion of the core are the secondary windings. Paralleled windings in the secondary assure a fast step response. The circuitry between the transformer and the coaxial cable corrects any differences in level between the signal induced in the parallel windings of the secondary and matches the balanced probe winding to the cable.

As indicated on the probe body, the turns ratio of the P6021 is 125:1. This refers to the number of windings in the secondary of the probe transformer.

The probe transformer is shielded to eliminate interference from outside signals. To eliminate the possibility of creating a short circuit from this shield to the conductor being measured, the slide switch disconnects the ground from the shield when you open the sliding portion of the probe to connect or remove it from a conductor.

### Termination

The P6021 termination consists of a 62.5  $\Omega$  impedance-matching network to terminate the coaxial cable and a voltage divider that is switched in by a sensitivity control to change the sensitivity by a factor of five. When the control is in the 2 mA/mV position, a 10 mA current signal in the conductor under test induces a 5 mV signal at the output of the termination. (This assumes that the termination is connected to a 1 M $\Omega$  input oscilloscope.)

When the sensitivity control is in the 10 mA/mV position, a 10 mA current signal is attenuated to induce a 1 mV signal at the output of the termination.

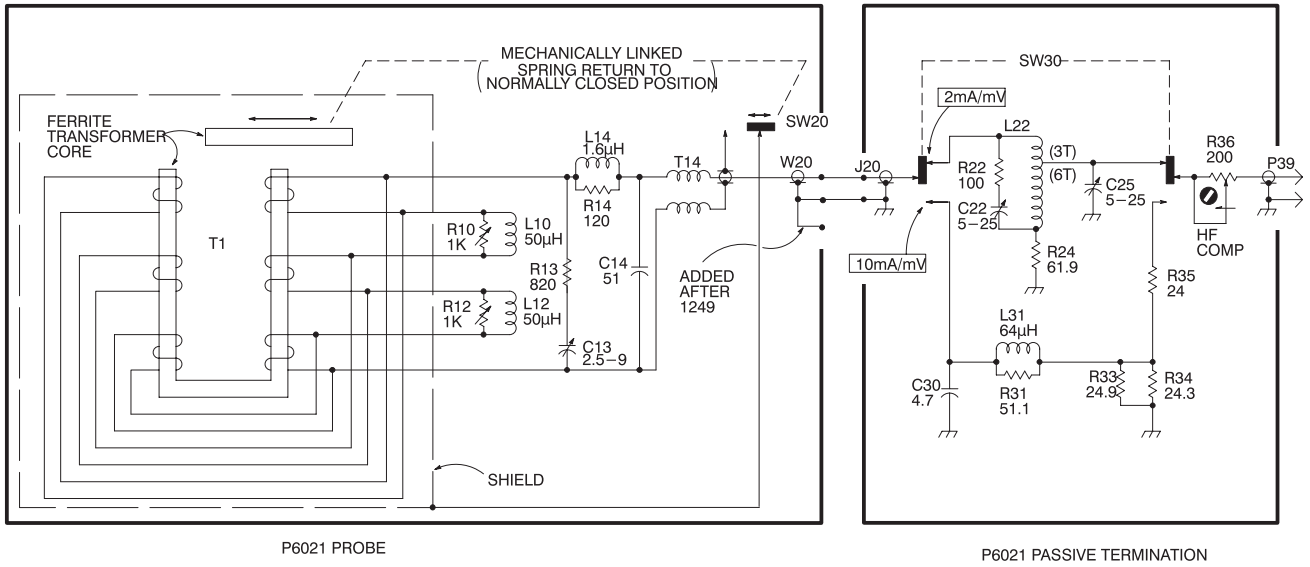

Figure 5: P6021 schematic diagram

## Performance Verification



---

**WARNING.** *To avoid personal injury and damage to the probe, remove the probe from any signal source before attempting to adjust or service the probe.*

*This probe should be serviced only by qualified service personnel.*

*Do not service electrical equipment alone. If you must service or adjust equipment that is attached to a signal or power source, do so only when another person capable of rendering first aid and resuscitation is present.*

---

This section provides procedures to check the performance of the P6021 or to calibrate it. These procedures require the equipment listed in Table 7. Specifications given are the minimum necessary for accuracy. If equipment is substituted, it must meet or exceed the specifications of the recommended equipment. Test equipment is assumed to be correctly calibrated and operating within the given specifications.

Also, if equipment is substituted, control settings or equipment setup may need to be altered. For detailed operating instructions for the test equipment, refer to the instruction manual for each unit.

To ensure measurement accuracy, check the performance of the probe and termination whenever you begin using them with a different oscilloscope input, especially when you have changed input capacitance. Recalibrate the probe if necessary.

The recommended calibration interval of the probe and termination is every twelve months.

Before calibrating the probe, thoroughly inspect and clean it as described in the section entitled *Maintenance*. Dirty or worn mating surfaces between the transformer and the lid can degrade low-frequency response. Clean these surfaces if necessary.

Calibration procedures can also be used as performance checks by completing all steps except those that adjust the probe. This checks the probe and termination to the original performance standards without requiring you to remove the termination cover or make internal adjustments.

Table 7: Equipment list

Item	Description	Recommended equipment <sup>1</sup>
Oscilloscope		TDS 420A, TDS 303X, or TDS 305X
Bandwidth	DC to $\geq 200$ MHz	
Vertical sensitivity	1 mV/div	
Measurement functions	Amplitude, pk-pk, gated measurements, averaging	
Calibration generator		
Fast rise step	$\leq 1$ ns, 1 V <sub>p-p</sub> into 50 $\Omega$	Wavetek 9100 with option 100:250 or Tektronix PG 506A
Sinewave current	0.5 A <sub>p-p</sub> to 15 A <sub>p-p</sub> , 120 Hz to 10 kHz, $\leq \pm 0.60\%$	Wavetek 9100
Sinewave voltage	0.9 A <sub>p-p</sub> , 30 kHz, $\leq \pm 0.60\%$ 5 V <sub>p-p</sub> into 50 $\Omega$ (100 mA), 50 kHz to $>60$ MHz, 1.5% flatness	Wavetek 9100 with option 100:250, Tektronix SG 5030, SG 503
Digital Multimeter (DMM)	5 1/2 digits or better	Keithley 2000, HP 3458A
RMS ACV	50 mV to 1.0 V, 10 kHz, $\leq \pm 0.35\%$ 30 mV to 160 mV, 30 kHz, $\leq \pm 0.45\%$	
Coaxial cable	50 $\Omega$ , as specified for voltage sinewave and pulse waveform calibrator outputs	Matching SG 503, PG 506A or Wavetek 9100 cable
Termination, feedthrough BNC	50 $\Omega$	Tektronix Part Number 011-0049-01
Two attenuators	10X, 50 $\Omega$	Tektronix Part Number 011-0059-02
Coaxial cable	36-inch, 50 $\Omega$ precision	Tektronix Part Number 012-0482-00
Adapter	BNC male to GR	Tektronix Part Number 017-0064-00
Fixture	Current probe, calibration	Tektronix Part Number 067-0559-00
Lead	4-inch, banana connectors	Pomona B-4 or P-4

<sup>1</sup> Or equivalent

## Adjustment Procedures

- Preparation**
1. Insert a small screwdriver between the cover and the termination near the part number, and gently pry up the top cover of the P6021 termination by twisting the screwdriver. Leave the bottom cover on, since it must be in place when the termination is in use.

2. Set up the oscilloscope as described below:

Vertical mode	CH 1
Horizontal mode	Main
Trigger source	CH 1
Trigger coupling	AC
Trigger mode	Peak-to-peak, auto
Trigger slope	Positive
Trigger level	As required
Ch 1 coupling	DC
Ch 1 resistance	1 M $\Omega$
Volts/division	2 mV
Time/division	10 ns
Averages	5 to 10

---

**NOTE.** When using a digitizing oscilloscope, set averaging on to increase resolution.

When using a Wavetek 9100 calibrator with the scopecal option, no other calibrators are required. The following setups are generic with nominal settings indicated for the major adjustment steps.

---

3. Set up the fast rise step calibrator as described below:

Output	1 V <sub>p-p</sub>
Repetition rate	≥10 kHz

4. Set up the sine wave calibrator as described below:

Frequency	Ref 50 kHz
Amplitude	5 V <sub>p-p</sub>

---

**NOTE.** Dirty or worn mating surfaces between the transformer and the lid degrade the low-frequency response. Clean and inspect them before performing the following procedures. See page 26 for cleaning instructions.

---

## Adjust Aberrations



---

**CAUTION.** To avoid damaging the probe, do not disconnect the probe termination when measuring high currents. Leaving the probe unterminated can cause a high voltage to develop in the secondary winding that may damage the current probe transformer.

---

1. Using the appropriate adapter, connect the current probe calibration fixture to the fast rise output of the calibration generator (positive-going transition  $\pm 0$ ).

2. Set the fast rise function:

For the Wavetek 9100, select the Aux (oscilloscope and auxiliary), and edge (step) waveform functions. Set the output for + transition, 100 kHz repetition rate, and 1V<sub>p-p</sub> output. The signal output is through the BNC connector on the rear of the signal generator.

Or, if you are using a PG506A, set the function to Fast Rise.

3. Connect the P6021 probe BNC connector to the termination.
4. Connect the P6021 termination to the oscilloscope Ch 1 input.
5. Set the P6021 termination sensitivity to 2 mA/mV.
6. Pulling back on the probe slide switch, connect the probe to the current probe calibration fixture.

Ensure that the current is flowing in the correct direction; the minus sign should be near the outside and the plus sign should be near the connectors, as shown in Figure 6. (The figure shows the probe slide switch held open so that the plus and minus signs are visible. When you close the probe, the front portion with the markings will disappear inside the calibration fixture.)

7. Turn on the test equipment.

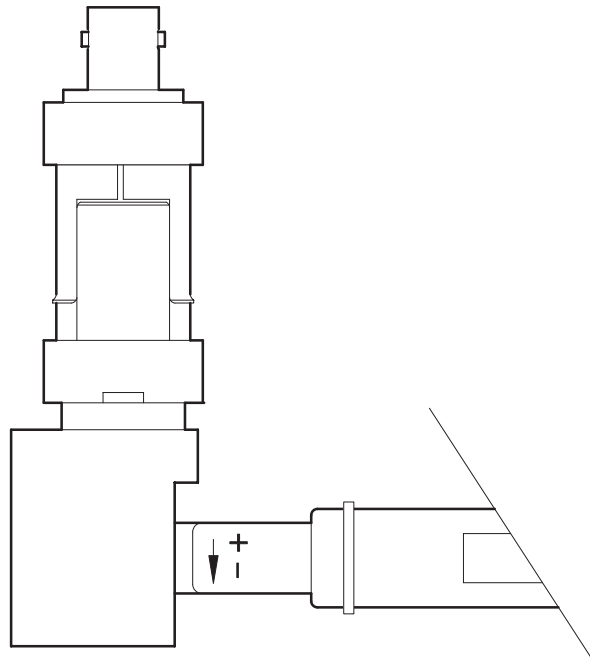

**Figure 6: Connecting the probe to the calibration fixture**

8. Adjust the oscilloscope position, triggering, intensity, and calibration generator amplitude controls until the signal is centered on the display (approximately five divisions peak to peak at 2 mV/div).
9. For the first 50 ns, aberrations should be within 10% peak to peak. After the first 50 ns, aberrations should be less than 2% peak to peak. To check for compliance, follow steps 9a through 9NO TAG.

**Termination Sensitivity at 2 mA/mV.**

- a. Turn on averaging and set the number of averages to 400 for verification, or 16 for adjustment.
- b. Turn on amplitude and peak-to-peak measurement functions. Check that the amplitude measurement function is set up to use the histogram method to determine pulse topline and baseline reference levels.
- c. Set the horizontal timebase to 50 ns/div and the pretrigger position to 20%. Adjust the position and trigger controls for a vertically centered pulse display with approximately 2 divisions of baseline and 8 divisions of topline displayed. This will allow for an accurate pulse amplitude reference measurement at 50 ns/div.

- d. Adjust the calibrator output for a 10.0 mV amplitude measurement. Allow time for the averaged value to settle. Do not use the peak-to-peak measurement when setting the pulse reference amplitude.
- e. Turn on the gating measurement mode and use the gated cursors and peak-to-peak measurement to verify the aberration specification, which are peak-to-peak tolerances.
- f. Select 10 ns/div to verify the first 50 ns specification and 50 ns/div to verify the >50 ns specification. Position the gated cursors to define the measurement zones for each case.

With the oscilloscope at 2 mV/div, 10% =1 mV or 0.5 division;  
2% =0.2 mV or 0.1 division (for a reference 10 mV<sub>p-p</sub> signal).

10. The following adjustments affect aberrations and flat-top response: C13, R10, and R12 of the probe (see Figure 7) and C22, C25, and R36 of the termination (see Figure 8). To minimize aberrations and achieve the best flat-top response, the following procedure is recommended. However, these adjustments interact; you may have to readjust several of them to ensure minimum aberrations..
- a. Adjust R10 and R12 for flat response. (Controls overshoot in the first 10 ns time domain.)
  - b. Adjust C13 for flat response. (Controls slope in first 20 ns.)
  - c. Adjust R36 for flat response. (Controls front corner, first 5 ns.)
  - d. Adjust C25 to minimize wrinkles in the 10 to 20 ns domain.
  - e. Adjust C22 to minimize wrinkles in the 15 to 25 ns domain.

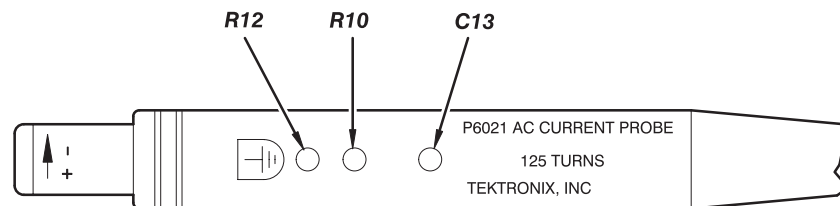
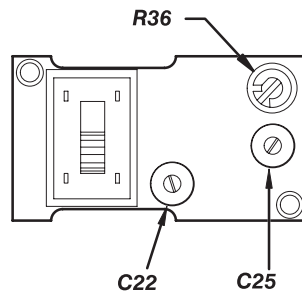

Figure 7: Location of probe adjustments



**Figure 8: Location of termination adjustments**

11. Set the termination sensitivity control to the 10 mA/mV position.
12. Set the oscilloscope vertical deflection to 1 mV/division.
13. Adjust the oscilloscope position, triggering, intensity, and calibration generator amplitude controls until the signal is centered on the display. Make certain that you can see the top of the waveform.
14. Check again to make sure that the aberrations are within the specifications described in Step 9, beginning on page 18.

**Termination Sensitivity at 10 mA/mV (Functional Check).**

1. If the gated measurement mode is still active, verify the gated zone is for the full displayed window.
2. Repeat steps 9a through 9f, except set the digital oscilloscope to 1 mV/div and adjust for a 2.00 mV amplitude display at 50 ns/div.
3. Check aberrations as for the 2 mA/mV position using the gated zone, peak-to-peak measurements. For this case, 10% = 0.2 mV or 200  $\mu$ V; 2% = 0.04 mV or 40  $\mu$ V.

**Measurement notes:**

For the 2% measurement, you may have to increase the averaging to 400 or greater to minimize noise. If the average reading fluctuates, use the average of these fluctuations or turn on statistics (if available) and use a weighted mean value.

Digital oscilloscopes with zoom mode can increase resolution. Noise and statistical variations will limit the useful resolution.

Turn gating off after completing measurements.

All of the adjustments interact; you may have to repeat adjustments to meet all specifications.

**Check Sensitivity**

1. Verify that the calibrator is off before making any circuit connections. Disconnect any other connections to the calibrator before starting these checks.
2. Connect the 4-inch lead across the **I+** and **I-** terminals of the calibrator.
3. Connect the current probe jaws around the lead, observing correct polarity. The probe jaws must be clean, aligned around the lead, and properly closed for accurate measurements.
4. Connect the probe output to the termination box.
5. Connect the termination box output to the DMM input terminals using a BNC-to-banana adapter.
6. Select the **2 mA/mV** position for the termination box.
7. Set the DMM to **ACV**, slow, or the most accurate sample rate, auto-range.
8. Set the calibrator to the ACI function by pressing the **A** (current) and **~A** buttons.

---

***NOTE.** For all of the following tests, the DMM voltage readings and calibrator settings are in RMS units, unless otherwise specified. You may have to manually select a lower range on the DMM to enhance the accuracy and resolution of your measurements.*

---

**2 mA/mV Sensitivity Tests:**

1. Check that the termination is set to the **2 mA/mV** position.
2. Set the calibrator for a **10 kHz, 1.76777 A** ( $5 A_{p-p}$ ) output. Verify that the delta % function is turned off.
3. Turn the output on and allow the DMM reading to stabilize. The DMM must read between 0.857 and 0.911 volts (0.884 V nominal).
4. Select the **÷ 10** button on the calibrator (10 kHz,  $0.5 A_{p-p}$ ).
5. Allow the DMM reading to stabilize. The DMM must read between 85.7 and 91.1 mV (88.4 mV nominal).
6. Set the calibrator output to **318.198 mA** ( $0.90 A_{p-p}$ ).
7. Change the calibrator frequency to **30 kHz**.
8. Allow the DMM reading to stabilize. The DMM must read between 0.1543 and 0.1639 V (0.1591 V nominal).
9. Set the calibrator output to off.

### 10 mA/mV Sensitivity Tests:

1. Select the **10 mA/mV** position on the termination box.
2. Set the calibrator for a **10 kHz, 5.3033 A** (15 A<sub>p-p</sub>) output. Verify that the delta % function is turned off.
3. Turn the output on and allow the DMM reading to stabilize. The DMM must read between 0.514 and 0.546 volts (0.530 V nominal).
4. Select the  $\div$  **10** button on the calibrator (10 kHz, 1.5 A<sub>p-p</sub>).
5. Allow the DMM reading to stabilize. The DMM must read between 51.4 and 54.6 mV (53.0 mV nominal).
6. Set the calibrator output to **318.198 mA** (0.90 A<sub>p-p</sub>).
7. Change the calibrator frequency to **30 kHz**.
8. Allow the DMM reading to stabilize. The DMM must read between 30.87 and 32.77 mV (31.82 mV nominal).
9. Set the calibrator output to off. Do not change any circuit connections.

---

**NOTE.** The attenuators that you use should be calibrated so that you can determine their error.

---

### Check Low Frequency Response

The following tests use a digital oscilloscope. Variable volts/div, averaging, and automatic peak-to-peak measurement functions will yield the best accuracy. However, a digitizer without these functions may be used as long as the minimum bandwidth specification is met, as specified in the equipment list.

### 2 mA/mV Position Test:

1. Connect the probe as you have for the sensitivity checks, except connect the termination output to the input of the digitizer. Set the BNC-to-banana adapter aside.
2. Set the termination box to the **2 mA/mV** position.
3. Set the digital oscilloscope input impedance to 1 M, DC coupled, sample mode (averaging off).
4. Set the oscilloscope vertical sensitivity to **100 mV/div** and the horizontal scale to **20  $\mu$ s/div**.
5. Set the calibrator for a **10 kHz, 0.35355 A** (1 A<sub>p-p</sub>) output with the delta % function is turned off.

6. Turn on the calibrator output.
7. Adjust the digital oscilloscope triggering for a centered waveform of approximately 500 mV<sub>p-p</sub>.
8. Adjust the fine volts/div for a near full-screen vertical waveform. Nominal deflection at 500 mV/div will be 5 divisions. A digitizer with adjustable volts/div can increase resolution to approximately 8 divisions.
9. Choose the peak-to-peak measurement function of the oscilloscope and fine-adjust the calibrator output for a 500 mV<sub>p-p</sub> digitizer reading by selecting and varying the % delta output control of the calibrator.
10. Turn on averaging (16 or greater), and readjust the calibrator output if necessary to obtain a stable 500 mV<sub>p-p</sub> reading. Allow sufficient time for the measurement to update with averaging turned on.
11. If your digitizer only supports cursor measurements, adjust the cursor readout for the nominal 500 mV<sub>p-p</sub> and adjust the calibrator output for a peak-to-peak amplitude waveform that corresponds to the cursor settings. You may have to adjust the oscilloscope offset to center the waveform between the cursors.
12. For the remainder of this test, 500 mV<sub>p-p</sub> is the reference reading.
13. Change the calibrator output frequency to **450 Hz**.
14. Set the oscilloscope horizontal sensitivity to **500 µs/div** to obtain a centered waveform. Turn averaging off to provide for a quicker waveform update.
15. Turn averaging on.
16. Allow the oscilloscope averaged reading to stabilize. The peak-to-peak amplitude reading must be  $\geq 354$  mV<sub>p-p</sub> ( $0.707 * 500$  mV<sub>p-p</sub> reference amplitude). If using statistical averaging, allow enough update time for the mean value to stabilize.
17. If using cursors to take this measurement, adjust the cursors to measure the peak-to-peak amplitude. Use averaging if possible.
18. Set the calibrator output to off. Do not change any circuit connections.

#### 10 mA/mV Position Test:

1. Set the termination box to the **10 mA/mV** position.
2. Set the oscilloscope vertical sensitivity to **50 mV/div** and the horizontal scale to **20 µs/div**.
3. Set the calibrator for a **10 kHz, 1.06066 A** (3 A<sub>p-p</sub>) output with the delta % function is turned off.

4. Turn on the calibrator output.
5. Adjust the digital oscilloscope triggering for a centered waveform of approximately 300 mV<sub>p-p</sub>.
6. Adjust the fine volts/div for a near full-screen vertical waveform. Nominal deflection at 50 mV/div will be 6 divisions. A digitizer with adjustable volts/div can increase resolution to approximately 8 divisions.
7. Choose the peak-to-peak measurement function of the oscilloscope and fine-adjust the calibrator output for a 300 mV<sub>p-p</sub> digitizer reading by selecting and varying the % delta output control of the calibrator.
8. Turn on averaging (16 or greater), and readjust the calibrator output if necessary to obtain a stable 300 mV<sub>p-p</sub> reading. Allow sufficient time for the measurement to update with averaging turned on.
9. If your digitizer only supports cursor measurements, adjust the cursor readout for the nominal 300 mV<sub>p-p</sub> and adjust the calibrator output for a peak-to-peak amplitude waveform that corresponds to the cursor settings. You may have to adjust the oscilloscope offset to center the waveform between the cursors.
10. For the remainder of this test, 300 mV<sub>p-p</sub> is the reference reading .
11. Change the calibrator output frequency to **120 Hz**.
12. Set the oscilloscope horizontal sensitivity to **2 ms/div** to obtain a centered waveform. Turn averaging off to provide for a quicker waveform update.
13. Turn averaging on.
14. Allow the oscilloscope averaged reading to stabilize. The peak-to-peak amplitude reading must be  $\geq 212$  mV<sub>p-p</sub> ( $0.707 * 300$  mV<sub>p-p</sub> reference amplitude). If using statistical averaging, allow enough update time for the mean value to stabilize.
15. If using cursors to take this measurement, adjust the cursors to measure the peak-to-peak amplitude. Use averaging if possible.
16. Set the calibrator % delta to off.
17. Set the calibrator output to off.

## Check High Frequency Response

To achieve the highest accuracy when taking the following measurements, turn on averaging and use the peak-to-peak measurement function, rather than manual cursor measurements.

1. Connect the current probe calibration fixture to the sine wave generator output using the appropriate adapters.
2. Connect the probe to the current probe calibration fixture.
3. Ensure that the termination sensitivity is set to **2 mA/mV**.
4. Set the oscilloscope vertical deflection to **10 mV/div**.
5. Set the oscilloscope horizontal scale to **10  $\mu$ s/div**.
6. Set the sine wave calibrator frequency to **50 kHz** and **5 V<sub>p-p</sub>** output.
7. Adjust the sine wave amplitude for a **50 mV<sub>p-p</sub>** signal (5 divisions). Use the peak-to-peak measurement function and averaging (16 or greater) for measurements. You can increase the vertical resolution by fine-adjusting the volts/div to obtain nearly 8 divisions of deflection.
8. Increase the sine wave generator frequency until the signal amplitude is 35.4 mV. Adjust the oscilloscope time/division as necessary.
9. Check that the frequency of the sine wave generator is  $\geq 60$  MHz on the oscilloscope display.
10. Reset the sine wave generator frequency to **50 kHz**.
11. Reset the oscilloscope horizontal scale to **10  $\mu$ s/div**.
12. Decrease the amplitude of the sine wave generator output until the oscilloscope display is one division tall.
13. Set the oscilloscope vertical deflection to **2 mV/div**.
14. Set the termination sensitivity to **10 mA/mV**.
15. Adjust the sine wave amplitude for a **10 mV<sub>p-p</sub>** signal (5 divisions). Use the peak-to-peak measurement function and averaging (16 or greater) for measurements.
16. Increase the sine wave generator frequency until the signal amplitude is 7.07 mV. Adjust the oscilloscope time/division as necessary.
17. Check that the sine wave generator frequency is  $\geq 60$  MHz.

When you are done, disconnect all test equipment and replace the termination cover.

## Maintenance

The information in this section will help you maintain your probe for a long service life.



---

**CAUTION.** *To prevent damage to probe materials, avoid using chemicals that contain benzene, benzine, toluene, xylene, acetone, or similar solvents.*

*To avoid degrading the probe's performance, do not lubricate the polished mating surfaces of the transformer.*

---

### Cleaning

To clean the probe body, use a soft cloth dampened in a solution of mild detergent and water. To clean the core, open the jaw and clean the exposed core surfaces with a cotton swab dampened with isopropyl alcohol (isopropanol) or ethyl alcohol (fotocol or ethanol).

Do not lubricate the mating surfaces of the jaws. Any lubricant between the core pieces should be removed with a recommended solvent.

Do not use chemicals containing benzine, benzene, toluene, xylene, acetone, or similar solvents.

Do not use a petroleum based lubricant on the plastic. If the plastic slide assembly requires lubrication, use a silicone-based grease sparingly.

Do not immerse the probe in liquids or use abrasive cleaners.

When cleaning the probe, look for any excessive wear of the slide parts that might cause the probe to operate improperly. Dirty or worn mating surfaces between the transformer and the lid can degrade low-frequency response. Clean these surfaces if necessary.

### Disassembling the Probe

Use the following procedure to disassemble the probe for cleaning or repair. You will need a #1 Posidriv screwdriver. Work over a smooth, clean surface so that you can easily find any small pieces that may drop. Refer to Figure 9.



---

**CAUTION.** *To avoid degrading the performance of the probe, do not touch the polished mating surfaces of the transformer after cleaning.*

---

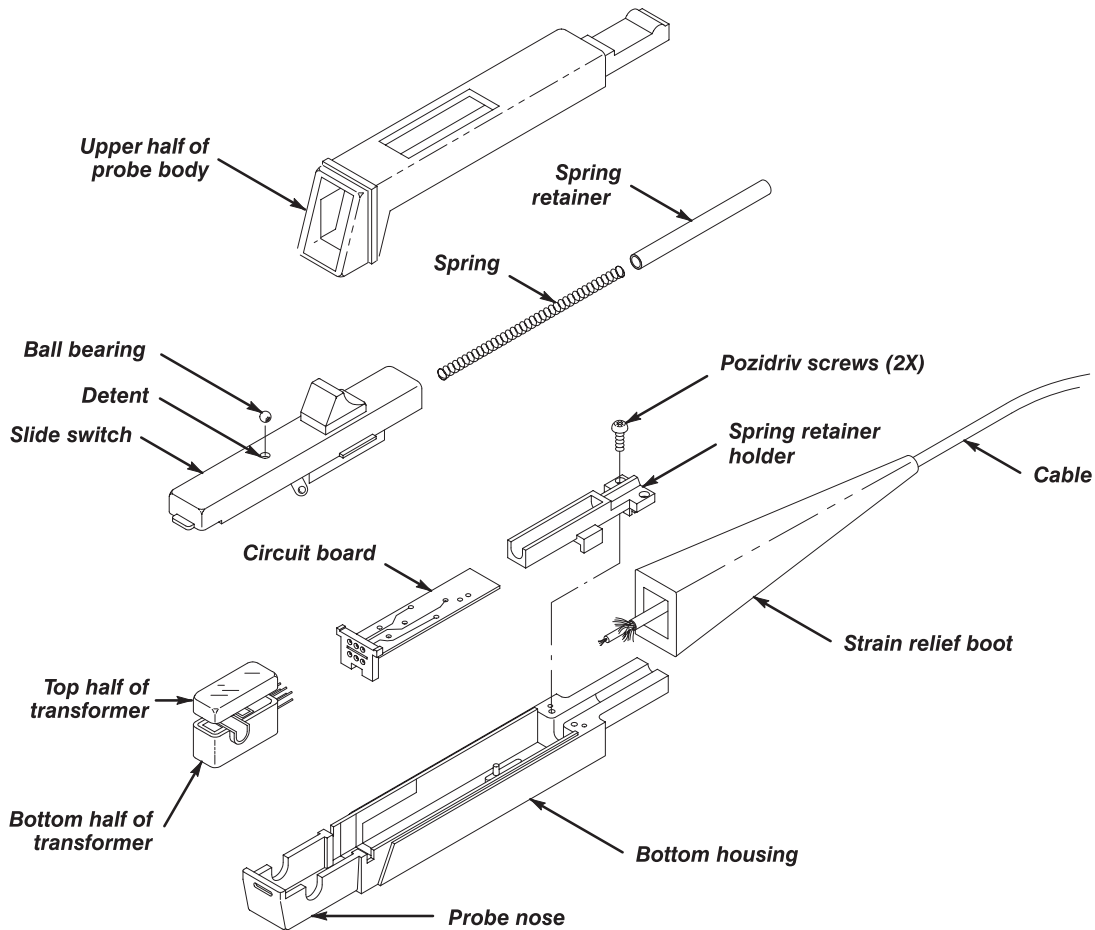

Figure 9: Disassembling the probe

1. Hold the probe horizontally with the slide switch up.
2. Move the strain relief boot back over the cable.
3. Be careful not to lose the small ball bearing you are about to expose.
4. Slowly lift the upper half of the probe body slightly at the cable end, and push the assembly forward over the nose and off.
5. Remove the small ball bearing from the detent in the slide switch.
6. Lift the back of the return spring retainer out of the holder.
7. Remove the slide switch, spring retainer, and the top of the transformer as a unit. Note the orientation of the movable portion of the transformer in the slide.

8. Remove the two Posidriv screws that secure the spring retainer holder to the probe body; then remove the small black plastic holder.
9. Lift the circuit board, transformer, and cable out of the probe body as a unit. If you need to, you can unplug the transformer from the circuit board.
10. To reassemble the probe, reverse the procedure above.

When replacing the slide switch, spring retainer, and transformer top as a unit, push the slide switch contacts gently inside the sides of the bottom housing.

### Repairing the Probe

To make repairs inside the probe body, disassemble the probe as described in the previous section. If you need to solder on the circuit board, use a minimum of heat, and observe normal circuit board procedures.

If you need to replace the current transformer, replace the entire assembly including the other half of the transformer core mounted in the slide switch. The transformer halves are matched at the factory before shipment.

### Repairing the Termination

Repairing the termination can consist of replacing either the connectors or the circuit board. These tasks are described below.

**Replacing the Connectors.** To replace the connectors, follow these steps.

1. Insert a small screwdriver between the cover and the termination near the part number, and gently pry up the plastic snap-on cover from the termination.
2. Using a heat sink, unsolder the leads from the defective connector.
3. Unscrew and remove the defective connector.
4. Replace the defective connector with the new one.
5. Screw and solder the new connector back in place.
6. Align the switch with the slider in the front cover, and replace the front cover.

**Replacing the Circuit Board.** To replace the circuit board, follow these steps.

1. Remove the plastic snap-on covers from the front and back of the termination.
2. Using a heat sink, unsolder the leads from the connectors.
3. Unscrew the two screws from the back of the circuit board.

4. Remove the circuit board from the termination and repair it as you require, being careful to use a minimum of heat and observe normal circuit board procedures.
5. Replace the circuit board by reversing the above procedure.
6. Align the switch with the slider in the front cover, and replace the front cover.



# Replaceable Electrical Parts

This section contains a list of the electrical components for the P6021. Use this list to identify and order replacement parts.

## Parts Ordering Information

Replacement parts are available through your local Tektronix field office or representative.

Changes to Tektronix products are sometimes made to accommodate improved components as they become available and to give you the benefit of the latest improvements. Therefore, when ordering parts, it is important to include the following information in your order:

- Part number
- Instrument type or model number
- Instrument serial number
- Instrument modification number, if applicable

If you order a part that has been replaced with a different or improved part, your local Tektronix field office or representative will contact you concerning any change in part number.

Change information, if any, is located at the rear of this manual.

## Using the Replaceable Electrical Parts List

The tabular information in the Replaceable Electrical Parts List is arranged for quick retrieval. Understanding the structure and features of the list will help you find all of the information you need for ordering replacement parts. The following table describes each column of the electrical parts list.

**Parts list column descriptions**

Column	Column name	Description
1	Component number	The component number appears on diagrams and circuit board illustrations, located in the diagrams section. Assembly numbers are clearly marked on each diagram and circuit board illustration in the <i>Diagrams</i> section, and on the mechanical exploded views in the <i>Replaceable Mechanical Parts</i> list section. The component number is obtained by adding the assembly number prefix to the circuit number (see Component Number illustration following this table).  The electrical parts list is arranged by assemblies in numerical sequence (A1, with its subassemblies and parts, precedes A2, with its subassemblies and parts).  Chassis-mounted parts have no assembly number prefix, and they are located at the end of the electrical parts list.
2	Tektronix part number	Use this part number when ordering replacement parts from Tektronix.
3 and 4	Serial number	Column three indicates the serial number at which the part was first effective. Column four indicates the serial number at which the part was discontinued. No entry indicates the part is good for all serial numbers.
5	Name & description	An item name is separated from the description by a colon (:). Because of space limitations, an item name may sometimes appear as incomplete. Use the U.S. Federal Catalog handbook H6-1 for further item name identification.
6	Mfr. code	This indicates the code number of the actual manufacturer of the part.
7	Mfr. part number	This indicates the actual manufacturer's or vendor's part number.

**Abbreviations**

Abbreviations conform to American National Standard ANSI Y1.1–1972.

**Component Number**

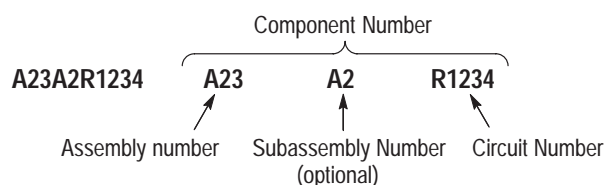

**Read: Resistor 1234 (of Subassembly 2) of Assembly 23**

**List of Assemblies**

A list of assemblies is located at the beginning of the electrical parts list. The assemblies are listed in numerical order. When a part's complete component number is known, this list will identify the assembly in which the part is located.

**Chassis Parts**

Chassis-mounted parts and cable assemblies are located at the end of the Replaceable Electrical Parts List.

**Mfr. Code to Manufacturer Cross Index**

The table titled Manufacturers Cross Index shows codes, names, and addresses of manufacturers or vendors of components listed in the parts list.

## Manufacturers cross index

<b>Mfr. code</b>	<b>Manufacturer</b>	<b>Address</b>	<b>City, state, zip code</b>
TK1727	PHILIPS NEDERLAND BV AFD ELONCO	POSTBUS 90050	5600 PB EINDHOVEN THE NETHERLANDS
OJR03	ZMAN MAGNETICS INC	7633 S 180th	KENT WA 98032
01121	ALLEN-BRADLEY CO	1201 S 2ND ST	MILWAUKEE WI 53204-2410
24931	SPECIALTY CONNECTOR CO INC	2100 EARLYWOOD DR PO BOX 547	FRANKLIN IN 46131
51642	CENTRE ENGINEERING INC	2820 E COLLEGE AVE	STATE COLLEGE PA 16801-7515
19701	PHILIPS COMPONENTS DISCRETE PRODUCTS DIV RESISTIVE PRODUCTS FACILITY AIRPORT ROAD	PO BOX 760	MINERAL WELLS TX 76067-0760
32997	BOURNS INC TRIMPOT DIV	1200 COLUMBIA AVE	RIVERSIDE CA 92507-2114
59660	TUSONIX INC	7741 N BUSINESS PARK DR PO BOX 37144	TUCSON AZ 85740-7144
79727	C-W INDUSTRIES	130 JAMES WAY	SOUTHAMPTON PA 18966-3818
80009	TEKTRONIX INC	14150 SW KARL BRAUN DR PO BOX 500	BEAVERTON OR 97077-0001
91637	DALE ELECTRONICS INC	2064 12TH AVE PO BOX 609	COLUMBUS NE 68601-3632

Replaceable electrical parts list

Component number	Tektronix part number	Serial no. effective	Serial no. discount'd	Name & description	Mfr. code	Mfr. part number
Figure 10						
A1	670-1117-00			CIRCUIT BD ASSY:PROBE	80009	670111700
A1C13	281-0122-00			CAP,VAR,CER DI:2.5-9PF,100V	59660	518-000A2.5-9
A1C14	283-0182-00			CAP,FXD,CER DI:51PF,5%,400V	19701	2805D1R810BH03F
A1L10	108-0526-00			COIL,RF:FIXED,50UH	OJR03	108-0526-00
A1L12	108-0526-00			COIL,RF:FIXED,50UH	OJR03	108-0526-00
A1L14	108-0529-00			COIL,RF:FIXED,1.6UH	OJR03	108-0529-00
A1R10	311-0635-00			RES,VAR,NONWW:TRMR,1K OHM,0.5W	32997	3329H-L58-102
A1R12	311-0635-00			RES,VAR,NONWW:TRMR,1K OHM,0.5W	32997	3329H-L58-102
A1R13	317-0821-00			RES,FXD,CMPSN:820 OHM,5%,0.125W	01121	BB8215
A1R14	317-0121-00			RES,FXD,CMPSN:120 OHM,5%,0.125W	TK1727	SFR16 2322-180-
A1T1	120-0614-00			TRANSFORMER,CUR:UPPER AND LOWER HALF	80009	120061400
A1T14	120-0468-00			XFMR,TOROID:6 TURNS,BIFILAR,454	OJR03	120-0468-00
A2	670-1052-00			CIRCUIT BD ASSY:TERMINATION	80009	670105200
A2C22	281-0123-00			CAP,VAR,CER DI:5-25PF,100V	59660	518-000A5-25
A2C25	281-0123-00			CAP,VAR,CER DI:5-25PF,100V	59660	518-000A5-25
A2C30	283-0140-00			CAP,FXD,CER DI:4.7PF,+/-0.25PF,50V	51642	A100-050-NPO-47
A2J20	131-0602-00			CONN,RF PLUG:BNC;50 OHM,MALE, STR,FEEDTHRU/Front PNL, 1.555L,0.285 L 0.375-32 THD,0.5	24931	28PR104-1
Figure 11						
A2L22	108-0525-00			COIL,RF:FIXED,123NH	OJR03	108-0525-00
A2L31	108-0395-00			COIL,RF:FIXED,64UH	OJR03	108-0395-00
A2P39	131-0106-02			CONN,RCPT,ELEC:BNC,FEMALE	24931	28JR178-1
A2R22	317-0101-00			RES,FXD,CMPSN:100 OHM,5%,0.125W	TK1727	SFR16 2322-180-
A2R24	321-0077-00			RES,FXD,FILM:61.9 OHM,1%,0.125W,TC=T0	91637	CMF55116G61R90F
A2R31	321-0069-00			RES,FXD,FILM:51.1 OHM,1%,0.125W,TC=T0	91637	CMF55116G51R10F
A2R33	321-0039-00			RES,FXD,FILM:24.9 OHM,1%,0.125W,TC=T0	91637	CMF55116G24R90F
A2R34	321-0038-00			RES,FXD,FILM:24.3 OHM,1%,0.125W,TC=T0	91637	CMF55116G24R30F
A2R35	317-0036-00		8843	RES,FXD,CMPSN:3.6 OHM,5%,0.125W	01121	BB36G5
A2R35	317-0240-00	8844		RES,FXD,CMPSN:24 OHM,5%,0.125W	TK1727	SFR16 2322-180-
A2R36	311-0605-00			RES,VAR,NONWW:TRMR,200 OHM,0.5W	32997	3329H-G48-201
A2SW30	260-0723-00			SWITCH,SLIDE:DPDT,0.5A,125VAC	79727	GF126-0028

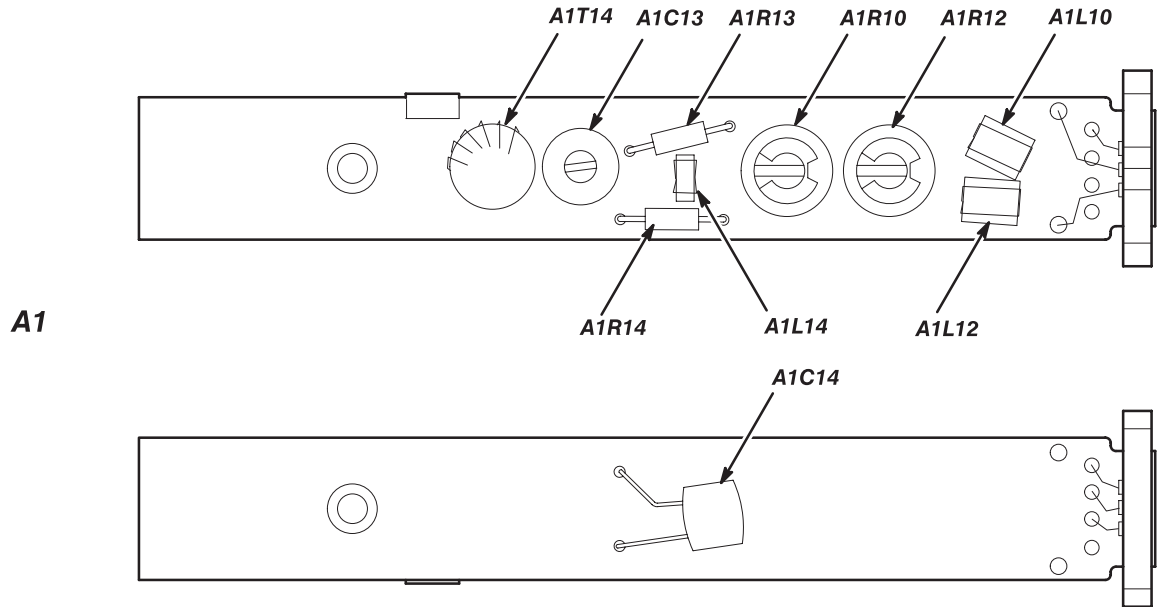

Figure 10: P6021 probe component location

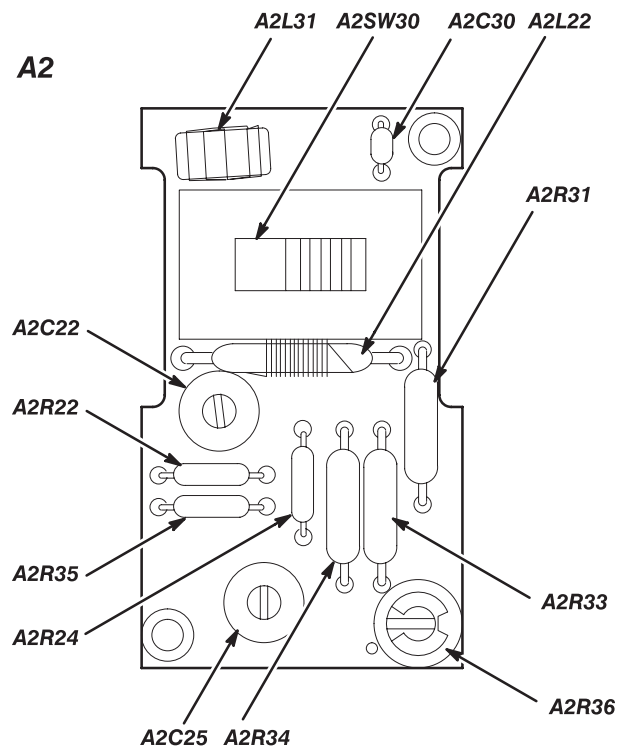

Figure 11: P6021 termination component location



# Replaceable Mechanical Parts

This section contains a list of the replaceable mechanical components for the P6021. Use this list to identify and order replacement parts.

## Parts Ordering Information

Replacement parts are available through your local Tektronix field office or representative.

Changes to Tektronix products are sometimes made to accommodate improved components as they become available and to give you the benefit of the latest improvements. Therefore, when ordering parts, it is important to include the following information in your order:

- Part number
- Instrument type or model number
- Instrument serial number
- Instrument modification number, if applicable

If you order a part that has been replaced with a different or improved part, your local Tektronix field office or representative will contact you concerning any change in part number.

Change information, if any, is located at the rear of this manual.

## Using the Replaceable Mechanical Parts List

The tabular information in the Replaceable Mechanical Parts List is arranged for quick retrieval. Understanding the structure and features of the list will help you find all of the information you need for ordering replacement parts. The following table describes the content of each column in the parts list.

**Parts list column descriptions**

Column	Column name	Description
1	Figure & index number	Items in this section are referenced by figure and index numbers to the exploded view illustrations that follow.
2	Tektronix part number	Use this part number when ordering replacement parts from Tektronix.
3 and 4	Serial number	Column three indicates the serial number at which the part was first effective. Column four indicates the serial number at which the part was discontinued. No entry indicates the part is good for all serial numbers.
5	Qty	This indicates the quantity of parts used.
6	Name & description	An item name is separated from the description by a colon (:). Because of space limitations, an item name may sometimes appear as incomplete. Use the U.S. Federal Catalog handbook H6-1 for further item name identification.
7	Mfr. code	This indicates the code of the actual manufacturer of the part.
8	Mfr. part number	This indicates the actual manufacturer's or vendor's part number.

**Abbreviations**      Abbreviations conform to American National Standard ANSI Y1.1–1972.

**Chassis Parts**      Chassis-mounted parts and cable assemblies are located at the end of the Replaceable Electrical Parts List.

**Mfr. Code to Manufacturer Cross Index**      The table titled Manufacturers Cross Index shows codes, names, and addresses of manufacturers or vendors of components listed in the parts list.

**Manufacturers cross index**

---

<b>Mfr. code</b>	<b>Manufacturer</b>	<b>Address</b>	<b>City, state, zip code</b>
TK0435	LEWIS SCREW CO	4300 S RACINE AVE	CHICAGO IL 60609-3320
0J9P9	GEROME MFG CO INC	PO BOX 737	NEWBERG OR 97132
00779	AMP INC	2800 FULLING MILL PO BOX 3608	HARRISBURG PA 17105
05469	BEARINGS INC	3634 EUCLID P O BOX 6925	CLEVELAND OH 44101
24931	SPECIALTY CONNECTOR CO INC	2100 EARLYWOOD DR PO BOX 547	FRANKLIN IN 46131
80009	TEKTRONIX INC	14150 SW KARL BRAUN DR PO BOX 500	BEAVERTON OR 97077-0001
91260	CONNOR SPRING AND MFG CO A SLOSS AND BRITTAN INC CO	1729 JUNCTION AVE	SAN JOSE CA 95112

Replaceable mechanical parts list

Fig. & index number	Tektronix part number	Serial no. effective	Serial no. discont'd	Qty	Name & description	Mfr. code	Mfr. part number
12-	-----			1	P6021,PROBE,CURRENT:60 MHZ,250A,5FT W/TERM		
-1	204-0367-02			1	.BODY HALF,PROBE:UPPER	80009	204036702
-2	214-0997-00			1	.BALL,BEARING:0.094,SST	05469	ORDER BY DESC
-3	351-0191-00			1	.SLIDE,TEST PROD:	80009	351019100
-4	214-0835-00			1	.SPRING,HLCPS:0.127 OD X 2.65 L,SST	91260	ORDER BY DESC
-5	214-0849-00			1	.RTNR RETURN SPR:BRS CD PL	80009	214084900
-6	131-0715-00			1	.CONTACT,ELEC:SPR,UPR SHL,CU BE NI PL	OJ9P9	131-0715-00
-7	-----			1	.TRANSFORMER:(SEE T1 REPL)		
-8	136-0252-00			6	.SOCKET,PIN TERM:PCB,;FEMALE,STR,ACCOM .0.013-.0.020 DIA PIN,TIN/TIN SLEEVE,CLOSED .BOTTOM.,0.142 L,0.038 DIA	00779	2-330808-7
-9	352-0158-00			1	.HOLDER,CKT BD:DELTRIN	80009	352015800
-10	-----			1	.CIRCUIT BD ASSY:PROBE(SEE A1 REPL)		
-11	352-0159-00			1	.HOLDER,SPR RTNR:BLACK DELTRIN ATTACHING PARTS	80009	352015900
-12	211-0001-00			2	.SCREW,MACHINE:2-56 X 0.25,PNH,STL END ATTACHING PARTS	TK0435	ORDER BY DESC
-13	204-0368-04			1	.BODY HALF,PROBE:LOWER	80009	204036804
-14	175-1041-03			1	.CABLE ASSY,RF:62.5 OHM COAX,63.0 L (STANDARD ONLY)	80009	175104103
	175-1060-03			1	.CABLE ASSY,RF:62.5 OHM COAX,111.0 L (OPTION 03 ONLY)	80009	175106003
-15	200-0852-08			1	.COVER,COAX TERM:W/SHLD & KNOB	80009	200085208
-16	131-0602-00			1	.CONN,RF PLUG::BNC,;50 OHM,MALE,STR, .FEEDTHRU./FRONT PNL, .1.555L,0.285 L .0.375-32 THD,0.5. L 22 AWG .TAB,0.384 DIA MTG	24931	28PR104-1
-17	426-0423-03			1	.FRAME,COAX TERM:	80009	426042303
-18	131-0106-02			1	.CONN,RCPT,ELEC:BNC,FEMALE	24931	28JR178-1
-19	361-0219-00			2	.SPACER,SLEEVE:0.06 L X 0.093 ID,BRS	80009	361021900
-20	-----			1	.CIRCUIT BD ASSY:TERMINATION(SEE A2 REPL) ATTACHING PARTS		
-21	211-0180-00			2	.SCR,ASSEM WSHR:2-56 X .0.25,PNH,BRS, .NP,POZ END ATTACHING PARTS	TK0435	ORDER BY DESC
-22	200-0851-03			1	.COV,COAX TERMN: <b>STANDARD ACCESSORIES</b>	80009	200085103
-23	196-3120-01			1	LEAD,ELEC,PROBE GROUND;SDI,23 AWG,6.0 L	80009	196312001
	070-0947-05			1	MANUAL,TECH:INSTRUCTION,P6021	80009	070094705
					<b>OPTIONAL ACCESSORIES</b>		
	-----			1	CT-4,CURRENT XFMR:20MHZ,1KA		

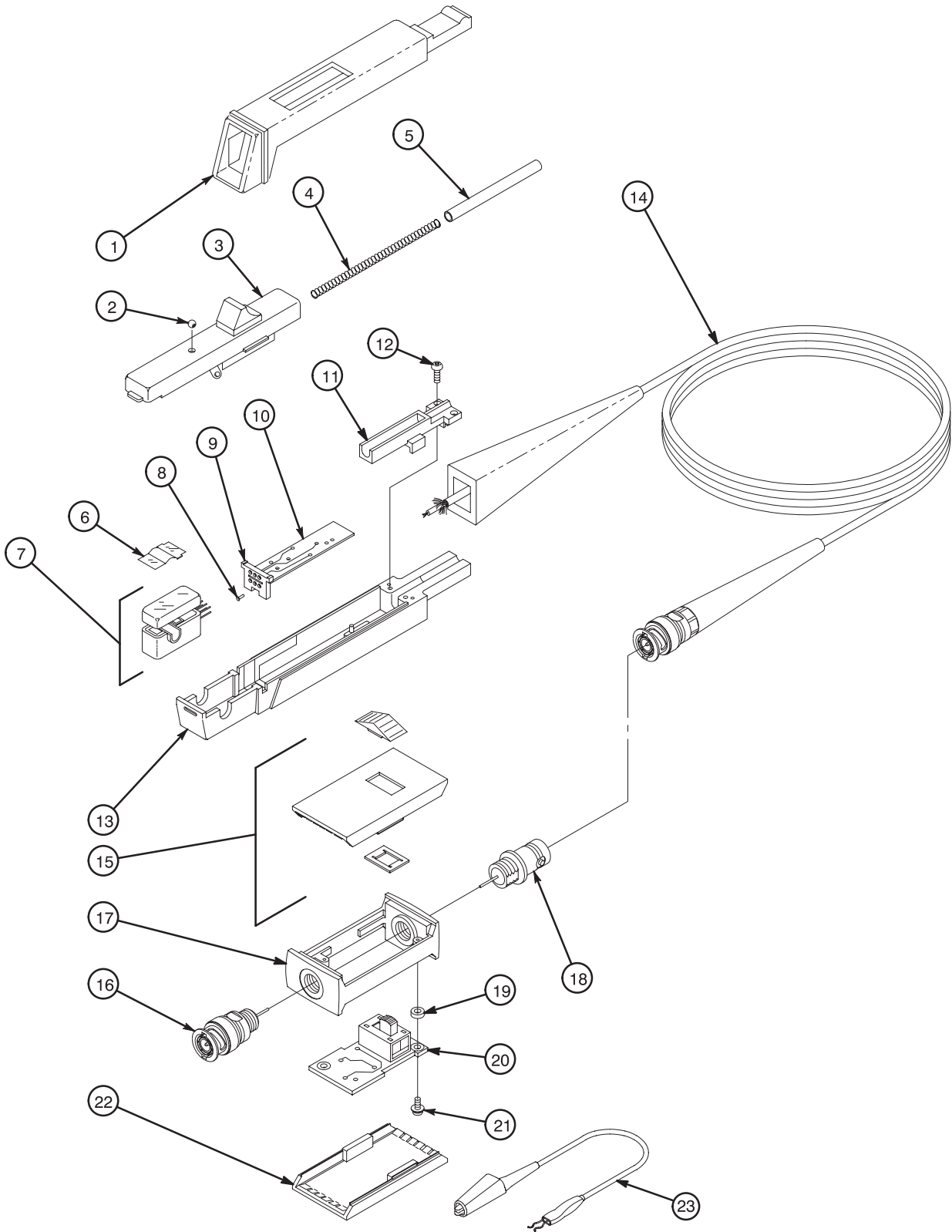

Figure 12: P6021 exploded view



# Index

## A

- aberrations, *17*
- accessories, termination, *1, 2*
- accessories, optional, *3*
- accessories, standard, *3–6*
  - 6-inch ground lead, *3*
  - instruction manual, *3*
- accuracy, *7*
- adjusting the probe, *19*
- adjusting the termination, *19*
- attaching the probe, *1–6*

## B

- bandwidth
  - checking, *22, 25*
  - specification, *7*

## C

- C13, *19*
- C22, *19, 20*
- C25, *19, 20*
- cable, 9-foot, *1*
- calibrating the probe, *14–30*
- Certifications, *9*
- checking performance, *14*
- circuit description, *12–30*
- cleaning the probe, *26*
- Compliances, *9*
- continuous current, maximum, *8*
- current flow, direction, *4*
- current vs. frequency derating, *9*

## D

- DC saturation, maximum, *10*
- direction of current flow, *4*
- disassembling the probe, *26–28*

## E

- electrical parts list, *31*
- electrical specifications, *7–30*
  - accuracy, *7*

- bandwidth, 7
- continuous current, maximum, 8
- DC saturation, maximum, 10
- input voltage, maximum, 8
- insertion impedance, 10
- pulse current, maximum, 8
- sensitivity, 7
- signal delay, 10
- tilt, 10
- environmental specifications, 11
  - altitude, 8
  - temperature, 8
- equipment for calibration, 15

## F

- ferrite core, 12
- frequency derating, 9

## G

- ground clips, using, 2
- ground lead, 6-inch, 3
- grounding the probe, 3, 5

## H

- high frequency response, 3, 25

## I

- impedance, 5, 12
  - of oscilloscope, 1, 12
  - probe, 5
- impedance-matching network, 12
- input voltage, maximum, 8
- insertion impedance, 5, 10
- instruction manual, 3
- interference, minimizing, 5, 6, 12

## L

- loading effect, minimizing, 5
- low frequency response, 22
- lubricating the probe, 26

## M

- magnetic shielding, 6
- maximum continuous current, 8

maximum DC saturation, *10*  
maximum input voltage, *8*  
maximum pulse current, *8*  
mechanical parts list, *37*

## O

Option 03, *1*  
options, cable, 9-foot, *1*  
oscilloscope, *1–3*  
    impedance, *1*  
    input connectors, *1*  
    use with, *1–6*

## P

parts list  
    electrical, *31*  
    mechanical, *37*  
phase response, *11*  
physical specifications, *11*  
    cable length, *11*  
    weight, *11*  
probe  
    adjustments, *17*  
    calibration, *14, 15*  
    circuit description, *12*  
    compatibility with oscilloscope, *1, 12*  
    description, *1–6*  
    disassembly, *26*  
    impedance of, *5*  
    parts, *2*  
    repair, *28*  
    shielding, *6, 12*  
pulse current, maximum, *8*

## R

R10, *19*  
R12, *19*  
R36, *19, 20*  
repairing  
    probe, *28*  
    termination, *28*  
replacing  
    termination circuit board, *28*  
    termination connectors, *28*  
    transformer, *28*

## S

- safety, service information, *14*
- schematic diagram, *13*
- sensitivity, *21*
  - checking, *21*
  - specification, *7*
- sensitivity control, *4, 7, 12*
- sensitivity setting, *4, 7, 12*
- service, safety warnings, *14*
- shielding, *6, 12*
- signal delay, *10*
- sliding switch, *4, 7, 12*
- soldering, procedures for, *28*
- specifications, *7–10*
  - electrical, *7–30*
  - environmental, *11*
  - physical, *11*

## T

- termination, *1, 2*
  - adjustments, *17*
  - circuit description, *12*
  - repair, *28*
  - replacing circuit board, *28*
  - replacing connectors, *28*
- test equipment, *15*
  - oscilloscope settings, *16*
  - pulse generator settings, *16*
  - recommended, *15*
- tilt, *10*
- transformer, *12*
  - maintenance, *26*
  - matching, *28*
  - primary, *4*
  - replacing, *28*
  - secondary, *4*
- turns ratio, *12*

## V

- vertical scale settings, with oscilloscope, *4*
- vertical sensitivity, *4, 12*
  - increasing, *5*
- voltage, maximum, *8*

## W

- winding, *5, 12*